

**CLASS X (2019-20)**  
**MATHEMATICS STANDARD(041)**  
**SAMPLE PAPER-2**

**Time : 3 Hours**

**Maximum Marks : 80**

**General Instructions :**

- (i) All questions are compulsory.
- (ii) The questions paper consists of 40 questions divided into 4 sections A, B, C and D.
- (iii) Section A comprises of 20 questions of 1 mark each. Section B comprises of 6 questions of 2 marks each. Section C comprises of 8 questions of 3 marks each. Section D comprises of 6 questions of 4 marks each.
- (iv) There is no overall choice. However, an internal choices have been provided in two questions of 1 mark each, two questions of 2 marks each, three questions of 3 marks each, and three questions of 4 marks each. You have to attempt only one of the alternatives in all such questions.
- (v) Use of calculators is not permitted.

## Section A

**Q.1-Q.10 are multiple choice questions. Select the most appropriate answer from the given options.**

1. The number  $3^{13} - 3^{10}$  is divisible by [1]  
 (a) 2 and 3 (b) 3 and 10  
 (c) 2, 3 and 10 (d) 2, 3 and 13

**Ans :** (d) 2, 3 and 13

$$3^{13} - 3^{10} = 3^{10}(3^3 - 1) = 3^{10}(26)$$

$$= 2 \times 13 \times 3^{10}$$

Hence,  $3^{13} - 3^{10}$  is divisible by 2, 3 and 13.

2. A can do a piece of work in 24 days. If B is 60% more efficient than A, then the number of days required by B to do the twice as large as the earlier work is [1]  
 (a) 24 (b) 36  
 (c) 15 (d) 30

**Ans :** (d) 30

Work ratio of  $A : B = 100 : 160$  or  $5 : 8$

Time ratio =  $8 : 5$  or  $24 : 15$

If A takes 24 days, B takes 15 days, Hence, B takes 30 days to do double the work.

3. Value (s) of  $k$  for which the quadratic equation  $2x^2 - kx + k = 0$  has equal roots is/are [1]  
 (a) 0 (b) 4  
 (c) 8 (d) 0, 8

**Ans :** (d) 0, 8

Given equation is,  $2x^2 - kx + k = 0$

On comparing with  $ax^2 + bx + c = 0$ ,

we get  $a = 2, b = -k$  and  $c = k$

For equal roots, the discriminant must be zero.

$$D = b^2 - 4ac = 0$$

$$(-k)^2 = -4(2)k = 0$$

$$k^2 - 8k = 0$$

$$k(k - 8) = 0$$

$$k = 0, 8$$

Hence, the required values of  $k$  are 0 and 8.

4. An AP starts with a positive fraction and every alternate term is an integer. If the sum of the first 11 terms is 33, then the fourth term is [1]  
 (a) 2 (b) 3  
 (c) 5 (d) 6

**Ans :** (a) 2

Given,  $S_{11} = 33$

$$\frac{11}{2}[2a + 10d] = 33 \Rightarrow a + 5d = 3$$

i.e.,  $a_6 = 3 \Rightarrow a_4 = 2$

[Since, Alternate terms are integers and the given sum is possible]

5. The areas of two similar triangles  $ABC$  and  $PQR$  are in the ratio  $9 : 16$ . If  $BC = 4.5$  cm, then the length of  $QR$  is [1]  
 (a) 4 cm (b) 4.5 cm  
 (c) 3 cm (d) 6 cm

**Ans :** (d) 6 cm

Since,  $\Delta ABC \sim \Delta PQR$

$$\frac{\text{ar}(\Delta ABC)}{\text{ar}(\Delta PQR)} = \frac{BC^2}{QR^2}$$

$$\frac{9}{16} = \frac{(4.5)^2}{QR^2}$$

$$QR^2 = \frac{16 \times (4.5)^2}{9}$$

$$QR = 6 \text{ cm}$$

6. If the points  $A(4, 3)$  and  $B(x, 5)$  are on the circle with centre  $O(2, 3)$ , then the value of  $x$  is [1]  
 (a) 0 (b) 1  
 (c) 2 (d) 3

**Ans :** (c) 2

Since,  $A$  and  $B$  lie on the circle having centre  $O$ .

$$OA = OB$$

$$\sqrt{(4-2)^2 + (3-3)^2} = \sqrt{(x-2)^2 + (5-3)^2}$$

$$2 = \sqrt{(x-2)^2 + 4}$$

$$4 = (x-2)^2 + 4$$

$$(x-2)^2 = 0$$

$$x = 2$$

7. If  $\sec 5A = \operatorname{cosec}(A + 30^\circ)$ , where  $5A$  is an acute angle, then the value of  $A$  is [1]  
 (a)  $15^\circ$  (b)  $5^\circ$   
 (c)  $20^\circ$  (d)  $10^\circ$

Ans : (d)  $10^\circ$

We have,  $\sec 5A = \operatorname{cosec}(A + 30^\circ)$   
 $\sec 5A = \sec[90^\circ - (A + 30^\circ)]$   
 $[\sec(90^\circ - \theta) = \operatorname{cosec} \theta]$   
 $\sec 5A = \sec(60^\circ - A)$   
 $5A = 60^\circ - A$   
 $6A = 60^\circ$   
 $A = 10^\circ$

8. If a regular hexagon is inscribed in a circle of radius  $r$ , then its perimeter is [1]  
 (a)  $3r$  (b)  $6r$   
 (c)  $9r$  (d)  $12r$

Ans : (b)  $6r$

Side of the regular hexagon inscribed in a circle of radius  $r$  is also  $r$ , the perimeter is  $6r$ .

9. The sides of a triangle (in cm) are given below. In which case, the construction of triangle is not possible. [1]  
 (a) 8, 7, 3 (b) 8, 6, 4  
 (c) 8, 4, 4 (d) 7, 6, 5

Ans : (c) 8, 4, 4

We know that, in a triangle sum of two sides of triangle is greater than the third side. Here, the sides of triangle given in option (c) does not satisfy this condition. So, with these sides the construction of a triangle is not possible.

10. Ratio of lateral surface areas of two cylinders with equal height is [1]  
 (a) 1 : 2 (b)  $H : h$   
 (c)  $R : r$  (d) None of these

Ans : (c)  $R : r$

$$2\pi Rh : 2\pi rh = R : r$$

**(Q.11-Q.15) Fill in the blanks.**

11. Numbers having non-terminating, non-repeating decimal expansion are known as ..... [1]

Ans : Irrational numbers

12. A quadratic polynomial can have at most 2 zeroes and a cubic polynomial can have at most ..... zeroes. [1]

Ans : 3

or

If  $\alpha, \beta, \gamma$  are the zeroes of the cubic polynomial  $ax^3 + bx^2 + cx + d = 0$ , then  $\alpha + \beta + \gamma = \frac{-b}{\dots\dots\dots}$

Ans : a

13. If radius of a circle is 14 cm the area of the circle is ..... [1]

Ans :  $616 \text{ cm}^2$

14. If the heights of two cylinders are equal and their radii are in the ratio of 7 : 5, then the ratio of their volumes

is ..... [1]

Ans : 49 : 25

15. If  $P(E) = 0.05$ , the probability of 'not  $E$ ' is ..... [1]

Ans : .95

**(Q.16-Q.20) Answer the following**

16. If one root of the quadratic equation  $6x^2 - x - k = 0$  is  $\frac{2}{3}$ , then find the value of  $k$ . [1]

Ans :

We have  $6x^2 - x - k = 0$

Substituting  $x = \frac{2}{3}$ , we get

$$6\left(\frac{2}{3}\right)^2 - \frac{2}{3} - k = 0$$

$$6 \times \frac{4}{9} - \frac{2}{3} - k = 0$$

$$k = 6 \times \frac{4}{9} - \frac{2}{3} = \frac{24 - 6}{9} = 2$$

Thus  $k = 2$ .

17. Two coins of diameter 2 cm and 4 cm respectively are kept one over the other as shown in the figure, find the area of the shaded ring shaped region in square cm. [1]

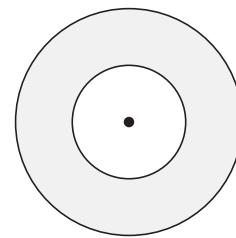

Ans :

$$\text{Area of circle} = \pi r^2$$

$$\text{Area of the shaded region} = \pi(2)^2 - \pi(1)^2$$

$$= 4\pi - \pi = 3\pi \text{ sq cm}$$

18. What is the ratio of the total surface area of the solid hemisphere to the square of its radius. [1]

Ans :

$$\frac{\text{Total surface area of hemisphere}}{\text{Square of its radius}} = \frac{3\pi r^2}{r^2} = \frac{3\pi}{1}$$

Total surface area of hemisphere : Square of radius

$$= 3\pi : 1$$

or

If the area of three adjacent faces of a cuboid are  $X, Y$ , and  $Z$  respectively, then find the volume of cuboid.

Ans :

Let the length, breadth and height of the cuboid is  $l, b$  and  $h$  respectively.

$$X = l \times b$$

$$Y = b \times h$$

$$Z = l \times h$$

$$XYZ = l^2 \times b^2 \times h^2$$

$$\text{Volume of cuboid} = l \times b \times h$$

$$l^2 b^2 h^2 = XYZ$$

or,  $lbh = \sqrt{XYZ}$

19. Find median of the data, using an empirical relation when it is given that Mode = 12.4 and Mean = 10.5. [1]

Ans :

$$\begin{aligned} \text{Median} &= \frac{1}{3} \text{ Mode} + \frac{2}{3} \text{ Mean} \\ &= \frac{1}{3}(12.4) + \frac{2}{3}(10.5) \\ &= \frac{12.4}{3} + \frac{21}{3} \\ &= \frac{12.4 + 21}{3} = \frac{33.4}{3} \\ &= \frac{33.4}{3} = 11.13 \end{aligned}$$

20. A game of chance consists of spinning an arrow which comes to rest pointing at one of the numbers 1, 2, 3, 4, 5, 6, 7, 8 and these are equally likely outcomes. Find the probability that the arrow will point at any factor of 8 ? [1]

Ans :

Given, Total number of points = 8  
 Total number of possible outcomes = 8  
 $= (1 \times 8), (2 \times 4), (8 \times 1), (4 \times 2)$   
 No. of favourable outcomes = 4  
 $\therefore P(\text{Factor of } 8) = \frac{\text{No. of favourable outcomes}}{\text{Total no. of possible outcomes}}$   
 $= \frac{4}{8} = \frac{1}{2}$

## Section B

21. In the figure given below, ABCD is a rectangle. Find the values of x and y. [2]

Ans :

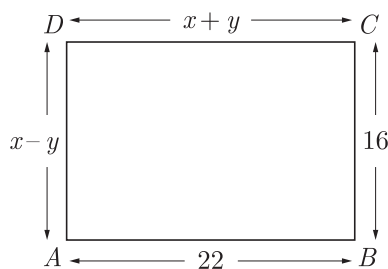

From given figure, we have

$$x + y = 22 \quad \dots(1)$$

and  $x - y = 16 \quad \dots(2)$

After adding equation (1) and (2), we have

$$2x = 38$$

$$x = 19$$

Substituting the value of x in equation (1), we get

$$19 + y = 22$$

$$y = 22 - 19 = 3$$

Hence,  $x = 19$  and  $y = 3$ .

22. In  $\Delta ABC$ ,  $AD \perp BC$ , such that  $AD^2 = BD \times CD$ .

Prove that  $\Delta ABC$  is right angled at A. [2]

Ans :

As per given condition we have drawn the figure below.

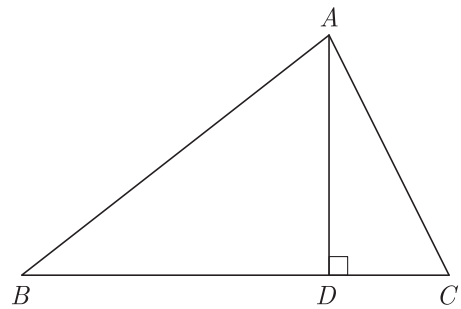

We have  $AD^2 = BD \times CD$

$$\frac{AD}{CD} = \frac{BD}{AD}$$

Since  $\angle D = 90^\circ$ , by SAS we have

$$\Delta ADC \sim \Delta BDA$$

and  $\angle BAD = \angle ACD$ ;

Since corresponding angles of similar triangles are equal

$$\angle DAC = \angle DBA$$

$$\angle BAD + \angle ACD + \angle DAC + \angle DBA = 180^\circ$$

$$2\angle BAD + 2\angle DAC = 180^\circ$$

$$\angle BAD + \angle DAC = 90^\circ$$

$$\angle A = 90^\circ$$

Thus  $\Delta ABC$  is right angled at A.

23. Prove that the point (3,0), (6,4) and (-1,3) are the vertices of a right angled isosceles triangle. [2]

Ans :

We have  $A(3,0)$ ,  $B(6,4)$  and  $C(-1,3)$

Now  $AB^2 = (3 - 6)^2 + (0 - 4)^2$   
 $= 9 + 16 = 25$

$$BC^2 = (6 + 1)^2 + (4 - 3)^2$$

$$= 49 + 1 = 50$$

$$CA^2 = (-1 - 3)^2 + (3 - 0)^2$$

$$= 16 + 9 = 25$$

$$AB^2 = CA^2 \text{ or, } AB = CA$$

Hence triangle is isosceles.

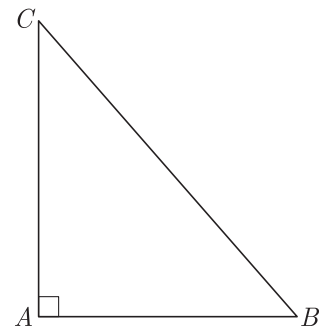

Also,  $25 + 25 = 50$

or,  $AB^2 + CA^2 = BC^2$

Since Pythagoras theorem is verified, therefore triangle is a right angled triangle.

or

Find the relation between  $x$  and  $y$ , if the point  $A(x, y), B(-5, 7)$  and  $C(-4, 5)$  are collinear.

Ans :

If the area of the triangle formed by the points is zero, then points are collinear.

$$\frac{1}{2}[x_1(y_2 - y_3) + x_2(y_3 - y_1) + x_3(y_1 - y_2)] = 0$$

$$[x(7 - 5) - 5(5 - y) - 4(y - 7)] = 0$$

$$2x - 25 + 5y - 4y + 28 = 0$$

$$2x + y + 3 = 0$$

24. One tends to become lazy. Also, starting at your mobile screen for long hours can affect your eyesight and give you headaches. Those who are addicted to playing PUBG can get easily stressed out or face anxiety issues in public due to lack of social interaction.

To raise social awareness about ill effects of playing PUBG, a school decided to start "BAN PUBG: campaign, students are asked to prepare campaign board in the shape of rectangle (as shown in the figure). [2]

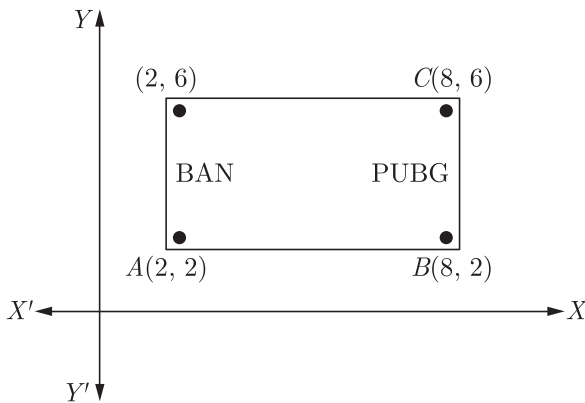

- (i) Find the area of the board.
- (ii) If cost of  $1 \text{ cm}^2$  of board is ₹8, then find the cost of board.

Ans :

(i) From the figure, we have

$$AB = \sqrt{(8 - 2)^2 + (2 - 2)^2}$$

$$= \sqrt{6^2 + (0)^2} = 6 \text{ cm}$$

$$BC = \sqrt{(8 - 8)^2 + (6 - 2)^2}$$

$$= \sqrt{(0)^2 + 4^2} = 4 \text{ cm}$$

$$\text{Area of board} = \text{Area of rectangle } ABCD$$

$$= AB \times BC$$

$$= 6 \times 4 = 24 \text{ cm}^2$$

- (ii) Total cost of board = Area of board  $\times$  Rate  
 $= 24 \times 8 = \text{₹}192$

25. The mean and median of 100 observation are 50 and 52 respectively. The value of the largest observation is 100. It was later found that it is 110. Find the true mean and median. [2]

Ans :

As we know that,

$$\text{Mean} = \frac{\sum fx}{\sum f}$$

$$\Rightarrow 50 = \frac{\sum fx}{100}$$

$$\Rightarrow \sum fx = 5000$$

$$\text{correct, } \sum fx' = 5000 - 100 + 110 = 5010$$

$$\therefore \text{Correct Mean} = \frac{5010}{100} = 50.1$$

Median will remain same i.e. median = 52.

or

There are 30 cards of the same size in a bag in which the numbers 1 to 30 are written. One card is taken out of the bag at random. Find the probability that the number on the selected card is not divisible by 3.

Ans :

Here,

$$\text{Total cards} = 30$$

$$\text{Number divisible by 3} = 3, 6, 9, 12, 15, 18, 21, 24, 27, 30$$

Total number of favourable outcomes

$$= 30 - 10 = 20$$

$$\therefore \text{required probability} = \frac{20}{30} = \frac{2}{3}$$

26. Pawan is fly fishing in a stream as shown in the figure. The tip of her fishing rod is 1.8 m above the surface of the water and the fly at the end of the string rests on the water 3.6 m away and 2.4 m from a point directly under the tip of the rod. [2]

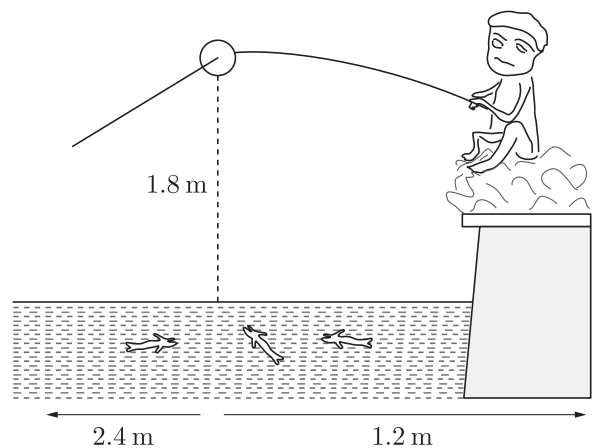

Assuming that her string (from the tip of her rod to the fly) is taut, how much string does she have out?

Ans :

Let the tip of her fishing rod be A. So, its distance from surface of water B is  $AB = 1.8 \text{ m}$

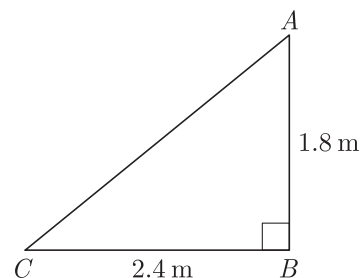

Again, let C be the point at 2.4 m away from B. Then, length of the string that she has out.

$$AC = \sqrt{(AB)^2 + (BC)^2}$$

[using Pythagoras theorem]

$$= \sqrt{(1.8)^2 + (2.4)^2}$$

$$= \sqrt{3.24 + 5.76}$$

$$= \sqrt{9} = 3 \text{ cm}$$

## Section C

27. If  $\alpha$  and  $\beta$  are the zeroes of the polynomial  $6y^2 - 7y + 2$ , find a quadratic polynomial whose zeroes are  $\frac{1}{\alpha}$  and  $\frac{1}{\beta}$ . [3]

**Ans :**

We have  $p(y) = 6y^2 - 7y + 2$

Sum of zeroes  $\alpha + \beta = -\left(-\frac{7}{6}\right) = \frac{7}{6}$

Product of zeroes  $\alpha\beta = \frac{2}{6} = \frac{1}{3}$

Sum of zeroes of new polynomial  $g(y)$

$$\frac{1}{\alpha} + \frac{1}{\beta} = \frac{\alpha + \beta}{\alpha\beta} = \frac{7/6}{2/6} = \frac{7}{2}$$

and product of zeroes of new polynomial  $g(y)$ ,

$$\frac{1}{\alpha} \times \frac{1}{\beta} = \frac{1}{\alpha\beta} = \frac{1}{1/3} = 3$$

The required polynomial is

$$g(x) = y^2 - \frac{7}{2}y + 3 = \frac{1}{2}[2y^2 - 7y + 6]$$

**or**

If  $\alpha, \beta$  and  $\gamma$  are zeroes of the polynomial  $6x^3 + 3x^2 - 5x + 1$ , then find the value of  $\alpha^{-1} + \beta^{-1} + \gamma^{-1}$ .

**Ans :**

We have  $p(x) = 6x^3 + 3x^2 - 5x + 1$

Since  $\alpha, \beta$  and  $\gamma$  are zeroes polynomial  $p(x)$ , we have

$$\alpha + \beta + \gamma = -\frac{b}{c} = -\frac{3}{6} = -\frac{1}{2}$$

$$\alpha\beta + \beta\gamma + \gamma\alpha = \frac{c}{a} = -\frac{5}{6}$$

and  $\alpha\beta\gamma = -\frac{d}{a} = -\frac{1}{6}$

Now  $\frac{1}{\alpha} + \frac{1}{\beta} + \frac{1}{\gamma} = \frac{\alpha\beta + \beta\gamma + \gamma\alpha}{\alpha\beta\gamma}$

$$= \frac{-5/6}{-1/6} = \frac{-5}{6} \times \frac{6}{-1} = 5$$

Hence  $\alpha^{-1} + \beta^{-1} + \gamma^{-1} = 5$ .

28. A part of monthly hostel charge is fixed and the remaining depends on the number of days one has taken food in the mess. When Swati takes food for 20 days, she has to pay Rs. 3,000 as hostel charges whereas Mansi who takes food for 25 days Rs. 3,500 as hostel charges. Find the fixed charges and the cost of food per day. [3]

**Ans :**

Let fixed charge be  $x$  and per day food cost be  $y$

$$x + 20y = 3000 \quad \dots(1)$$

$$x + 25y = 3500 \quad \dots(2)$$

Subtracting (1) from (2), we have

$$5y = 500 \Rightarrow y = 100$$

Substituting this value of  $y$  in equation (1), we get

$$x + 20(100) = 3000$$

$$x = 1000$$

Thus  $x = 1000$  and  $y = 100$

Fixed charge and cost of food per day are Rs. 1,000 and Rs. 100.

29. Divide 56 in four parts in A.P. such that the ratio of the product of their extremes ( $1^{st}$  and  $4^{th}$ ) to the product of means ( $2^{nd}$  and  $3^{rd}$ ) is 5:6. [3]

**Ans :**

Let the four numbers be  $a - 3d, a - d, a + d, a + 3d$

Now  $a - 3d + a - d + a + d + a + 3d = 56$

$$4a = 56 \Rightarrow a = 14$$

Hence numbers are  $14 - 3d, 14 - d, 14 + d, 14 + 3d$

Now, according to question,

$$\frac{(14 - 3d)(14 + 3d)}{(14 - d)(14 + d)} = \frac{5}{6}$$

$$\frac{196 - 9d^2}{196 - d^2} = \frac{5}{6}$$

$$6(196 - 9d^2) = 5(196 - d^2)$$

$$6 \times 196 - 54d^2 = 5 \times 196 - 5d^2$$

$$(6 - 5) \times 196 = 49d^2$$

$$d^2 = \frac{196}{49} = 4$$

$$d = \pm 2$$

Thus numbers are  $a - 3d = 14 - 3 \times 2 = 8$

$$a - d = 14 - 2 = 12$$

$$a + d = 14 + 2 = 16$$

$$a + 3d = 14 + 3 \times 2 = 20$$

Thus required AP is 8, 12, 16, 20.

**or**

If the sum of the first  $n$  terms of an A.P. is  $\frac{1}{2}[3n^2 + 7n]$ , then find its  $n^{th}$  term. Hence write its  $20^{th}$  term.

**Ans :**

Let the first term be  $a$ , common difference be  $d$ ,  $n$ th term be  $a_n$  and sum of  $n$  term be  $S_n$ .

Sum of  $n$  term  $S_n = \frac{1}{2}[3n^2 + 7n]$

Sum of 1 term  $S_1 = \frac{1}{2}[3 \times (1)^2 + 7(1)]$

$$= \frac{1}{2}[3 + 7]$$

$$= \frac{1}{2} \times 10 = 5$$

Sum of 2 term  $S_2 = \frac{1}{2}[3(2)^2 + 7 \times 2]$

$$= \frac{1}{2}[12 + 14]$$

$$= \frac{1}{2} \times 26$$

$$= 13$$

Now  $a_1 = S_1 = 5$

$$a_2 = S_2 - S_1 = 13 - 5 = 8$$

$$d = a_2 - a_1 = 8 - 5 = 3$$

Now, A.P. is 5, 8, 11, ....

$$\begin{aligned}
 n^{\text{th}} \text{ term, } \quad a_n &= a + (n - 1)d \\
 &= 5 + (n - 1)3 \\
 &= 5 + (20 - 1)(3) \\
 &= 5 + 57 \\
 &= 62
 \end{aligned}$$

Hence,  $a_2 = 62$

30.  $\Delta ABC$  is right angled at  $C$ . If  $p$  is the length of the perpendicular from  $C$  to  $AB$  and  $a, b, c$  are the lengths of the sides opposite  $\angle A, \angle B$  and  $\angle C$  respectively, then prove that  $\frac{1}{p^2} = \frac{1}{a^2} + \frac{1}{b^2}$ . [3]

Ans :

As per given condition we have drawn the figure below.

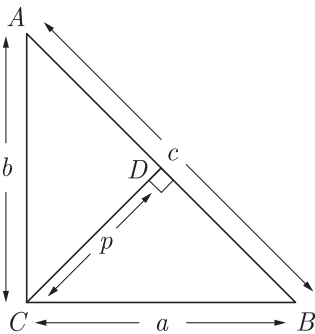

In  $\Delta ACB$  and  $\Delta CDB$

$$\begin{aligned}
 \angle ABC &= \angle CDB = 90^\circ \\
 \angle B &= \angle B \quad \text{(common)}
 \end{aligned}$$

Because of AA similarity, we have

$$\Delta ABC \sim \Delta CDB$$

Now

$$\begin{aligned}
 \frac{b}{p} &= \frac{c}{a} \\
 \frac{1}{p} &= \frac{c}{ab} \\
 \frac{1}{p^2} &= \frac{c^2}{a^2 b^2} \\
 \frac{1}{p^2} &= \frac{a^2 + b^2}{a^2 b^2} \\
 \frac{1}{p^2} &= \frac{1}{a^2} + \frac{1}{b^2} \quad \text{Hence Proved}
 \end{aligned}$$

31. From her elevated observation post 300 m away, a naturalist spots a troop of baboons high up in a tree. Using the small transit attached to her telescope, she finds the angle of depression to the bottom of this tree is  $30^\circ$ , while the angle of elevation to the top of the tree is  $60^\circ$ . The angle of elevation to the troop of baboons is  $45^\circ$ . Use this information to find (a) the height of the observation post, (b) the height of the baboons' tree, and (c) the height of the baboons above ground. [3]

Ans :

Let's first find the distances  $h_0, h_1$  and  $h_2$  in the diagram below, then answer the question.

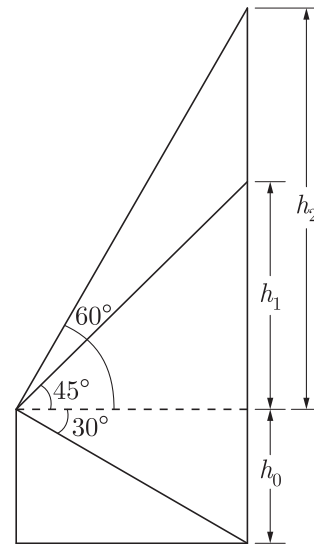

$$\begin{aligned}
 \tan 30^\circ &= \frac{h_0}{300}; \quad h_0 = 300 \tan 30^\circ \\
 &= \frac{300}{\sqrt{3}} \text{ m} = 100\sqrt{3}
 \end{aligned}$$

$$\tan 45^\circ = \frac{h_1}{300}; \quad h_1 = 300 \tan 45^\circ = 300 \text{ m}$$

$$\tan 60^\circ = \frac{h_2}{300}; \quad h_2 = 300 \tan 60^\circ = 300\sqrt{3}$$

- (a)  $h_0 = 100\sqrt{3}$  m is the height of the observation post.  
 (b)  $h_0 + h_1 = 100\sqrt{3} + 300 = 100(\sqrt{3} + 3)$  m ft. is the height of the tree.  
 (c)  $h_0 + h_1 = 100\sqrt{3} + 300 = 100(\sqrt{3} + 3)$  m ft. is the height of the baboons.

32. In the figure,  $PQ$  is a tangent to a circle with center  $O$ . If  $\angle OAB = 30^\circ$ , find  $\angle ABP$  and  $\angle AOB$ . [3]

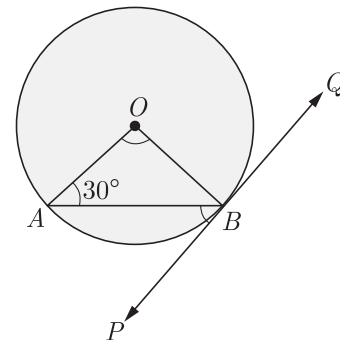

Ans :

Here  $OB$  is radius and  $QT$  is tangent at  $B$ ,  $OB \perp PQ$

$$\angle OBP = 90^\circ$$

Since the tangent is perpendicular to the end point of radius,

Here  $OA$  and  $OB$  are radius of circle and equal. Since angles opposite to equal sides are equal,

$$\angle OAB = \angle OBA = 30^\circ$$

$$\begin{aligned}
 \text{Now } \angle AOB &= 180^\circ - (30^\circ + 30^\circ) \\
 &= 120^\circ
 \end{aligned}$$

$$\begin{aligned}
 \angle ABP &= \angle OBP - \angle OBA \\
 &= 90^\circ - 30^\circ = 60^\circ
 \end{aligned}$$

or

A circle is inscribed in a  $\Delta ABC$ , with sides  $AC, AB$  and  $BC$  as 8 cm, 10 cm and 12 cm respectively. Find the length of  $AD, BE$  and  $CF$ .

**Ans :**

As per question we draw figure shown below.

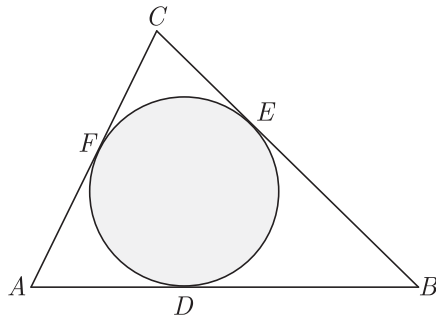

We have  $AC = 8$  cm  
 $AB = 10$  cm  
 and  $BC = 12$  cm

Let  $AF$  be  $x$ . Since length of tangents from an external point to a circle are equal,

At  $A$ ,  $AF = AD = x$  (1)

At  $B$   $BE = BD = AB - AD = 10 - x$  (2)

At  $C$   $CE = CF = AC - AF = 8 - x$  (3)

Now  $BC = BE + EC$   
 $12 = 10 - x + 8 - x$   
 $2x = 18 - 12 = 6$

or  $x = 3$

Now  $AD = 3$  cm,  
 $BE = 10 - 3 = 7$  cm

and  $CF = 8 - 3 = 5$

**33.** Construct a triangle similar to a given equilateral  $\Delta PQR$  with side 5cm such that each of its side is  $\frac{6}{7}$  of the corresponding sides of  $\Delta PQR$ . [3]

**Ans :**

**Steps of construction :**

1. Draw a line segment  $QR = 5$  cm.
2. With  $Q$  as centre and radius  $PQ = 5$ cm, draw an arc.
3. With  $R$  as center and radius  $= PR = 5$  cm, draw another arc meeting the arc drawn in step 2 at the point  $P$ .
4. Join  $PQ$  and  $PR$  to obtain  $\Delta PQR$ .
5. Below  $QR$ , construct an acute  $\angle RQX$ .
6. Along  $QX$ , mark off seven points  $Q_1, Q_2, \dots, Q_7$  such that  $QQ_1 = Q_1Q_2 = Q_2Q_3 = \dots = Q_6Q_7$ .
7. Join  $Q_7R$ .
8. Draw  $Q_6R' \parallel Q_7R$ .
9. From,  $R'$  draw  $R'P' \parallel RP$ .

Hence,  $P'QR'$  is the required triangle.

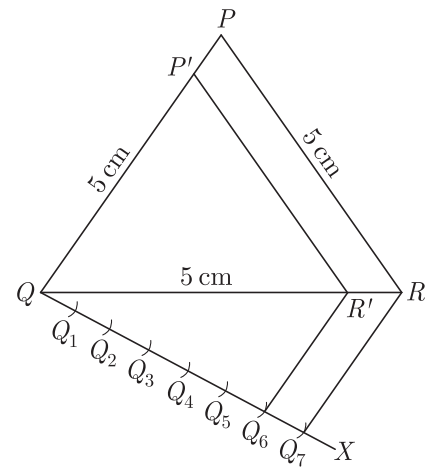

**34.** A boy, 1.4 metre tall standing at the edge of a river bank sees the top of a tree on the edge of the other bank at an elevation of  $55^\circ$ . Standing back by 3 metre, he sees it at elevation of  $45^\circ$ . [3]

- (a) Draw a rough figure showing these facts.
- (b) How wide is the river and how tall is the tree?  
 $[\sin 55^\circ = 0.8192, \cos 55^\circ = 0.5736, \tan 55^\circ = 1.4281]$

**Ans :**

(a) The rough sketch is as follows:

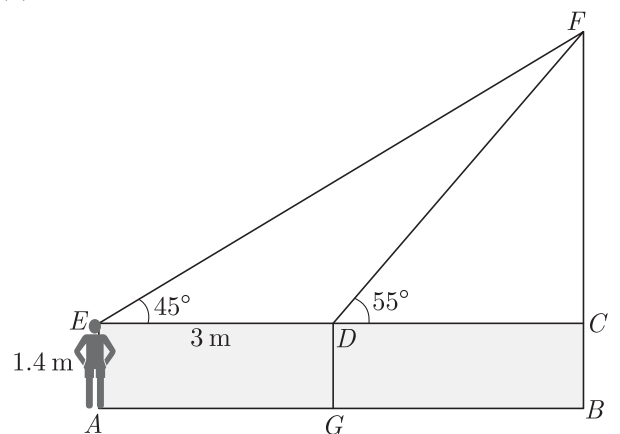

(b) Here,  $BF$  represents the tree, and  $CD$  represents the river.

$DG$  is the initial position of the boy and  $AE$  is the new position.

Here,  $AE = DG = BC = 1.4$  m

If  $DC = x$  m, then  $EC = (x + 3)$ m

In right  $\Delta ECF$ ,

$$\tan 45^\circ = \frac{CF}{EC} \Rightarrow 1 = \frac{CF}{x + 3}$$

$$CF = (x + 3)$$

In right  $\Delta DCF$ ,

$$\tan 55^\circ = \frac{CF}{DC} \Rightarrow 1.4281 = \frac{x + 3}{x}$$

$$1.4281x = x + 3$$

$$0.4281x = 3$$

$$x = \frac{3}{0.4281} = 7$$

Width of the river =  $CD = 7$  m

Height of the tree =  $BF + BC + CF$

$$= (1.4 + 7 + 3) = 11.4 \text{ m}$$

## Section D

**35.** Find HCF of 81 and 237 and express it as a linear combination of 81 and 237 i.e. HCF (81, 237) = 81x + 237y for some x and y. [4]

**Ans :**

By using Euclid's Division Lemma, we have

$$237 = 81 \times 2 + 75 \quad \dots(1)$$

$$81 = 75 \times 1 + 6 \quad \dots(2)$$

$$75 = 6 \times 12 + 3 \quad \dots(3)$$

$$6 = 3 \times 2 + 0 \quad \dots(4)$$

Hence, HCF (81, 237) = 3.

In order to write 3 in the form of 81x + 237y,

$$\begin{aligned} 3 &= 75 - 6 \times 12 \\ &= 75 - (81 - 75 \times 1) \times 12 && \text{Replace 6 from (2)} \\ &= 75 - 81 \times 12 + 75 \times 12 \\ &= 75 + 75 \times 12 - 81 \times 12 \\ &= 75(1 + 12) - 81 \times 12 \\ &= 75 \times 13 - 81 \times 12 \\ &= 13(237 - 81 \times 2) - 81 \times 12 && \text{Replace 75 from (1)} \\ &= 13 \times 237 - 81 \times 2 \times 13 - 81 \times 12 \\ &= 237 \times 13 - 81(26 + 12) \\ &= 237 \times 13 - 81 \times 38 \\ &= 81 \times (-38) + 237 \times (13) \\ &= 81x + 237y \end{aligned}$$

Hence x = -38 and y = 13. These values of x and y are not unique.

**or**

Show that there is no positive integer n, for which  $\sqrt{n-1} + \sqrt{n+1}$  is rational.

**Ans :**

Let us assume that there is a positive integer n for which  $\sqrt{n-1} + \sqrt{n+1}$  is rational and equal to  $\frac{p}{q}$ , where p and q are positive integers and (q ≠ 0).

$$\sqrt{n-1} + \sqrt{n+1} = \frac{p}{q} \quad \dots(1)$$

$$\begin{aligned} \text{or, } \frac{q}{p} &= \frac{1}{\sqrt{n-1} + \sqrt{n+1}} \\ &= \frac{\sqrt{n-1} - \sqrt{n+1}}{(\sqrt{n-1} + \sqrt{n+1})(\sqrt{n-1} - \sqrt{n+1})} \\ &= \frac{\sqrt{n-1} - \sqrt{n+1}}{(n-1) - (n+1)} \end{aligned}$$

$$\begin{aligned} \text{or } \frac{q}{p} &= \frac{\sqrt{n-1} - \sqrt{n+1}}{-2} \\ \sqrt{n+1} - \sqrt{n-1} &= \frac{2q}{p} \quad \dots(2) \end{aligned}$$

Adding (1) and (2), we get

$$2\sqrt{n+1} = \frac{p}{q} + \frac{2q}{p} = \frac{p^2 + 2q^2}{pq} \quad \dots(3)$$

Subtracting (2) from (1) we have

$$2\sqrt{n-1} = \frac{p^2 - 2q^2}{pq} \quad \dots(4)$$

**36.** Find x in terms of a, b and c : [4]

$$\frac{a}{x-a} + \frac{b}{x-b} = \frac{2c}{x-c}, x \neq a, b, c$$

**Ans :**

$$\text{We have } \frac{a}{x-a} + \frac{b}{x-b} = \frac{2c}{x-c}$$

$$\begin{aligned} a(x-b)(x-c) + b(x-a)(x-c) &= 2c(x-a)(x-b) \\ ax^2 - abx - acx + abc + bx^2 - bax - bcx + abc \\ &= 2cx^2 - 2cxb - 2cxa + 2abc \\ ax^2 + bx^2 - 2cx^2 - abx - acx - bax - bcx + 2cbx + 2acx &= 0 \end{aligned}$$

$$x^2(a+b-2c) - 2abx + acx + bcx = 0$$

$$x^2(a+b-2c) + x(-2ab+ac+bc) = 0$$

$$\text{Thus } x = -\left(\frac{ac+bc-2ab}{a+b-2c}\right)$$

**37.** If P(-5, -3), Q(-4, -6), R(2, -3) and S(1, 2) are the vertices of a quadrilateral PQRS, find its area. [4]

**Ans :**

We have P(-5, -3), Q(-4, -6), R(2, -3) and S(1, 2) Area of quadrilateral

$$= \frac{1}{2}[(x_1y_2 - x_2y_1) + (x_2y_3 - x_3y_2) + (x_3y_4 - x_4y_3) + (x_4y_1 - x_1y_4)]$$

$$\begin{aligned} \text{Area} &= \frac{1}{2}[-5(-6) - (-4)(-3) + (-4)(-3) - 2(-6) \\ &\quad + (2)(2) - 1 \times (-3) + 1 \times (-3) - (-5)(2)] \\ &= \frac{1}{2}[30 - 12 + 12 + 12 + 4 + 3 - 3 + 10] \\ &= \frac{1}{2}[30 + 12 + 4 + 10] = \frac{1}{2}[56] = 28 \text{ sq. units} \end{aligned}$$

**or**

If P(9a - 2, -b) divides the line segment joining A(3a + 1, -3) and B(8x, 5) in the ratio 3:1. Find the values of a and b.

**Ans :**

Using section formula we have

$$9a - 2 = \frac{3(8a) + 1 + (3a + 1)}{3 + 1} \quad \dots(1)$$

$$-b = \frac{3(5) + 1(-3)}{3 + 1} \quad \dots(2)$$

$$\text{Form (2)} \quad -b = \frac{15 - 3}{4} = 3 \Rightarrow b = -3$$

$$\text{From (1), } 9a - 2 = \frac{24a + 3a + 1}{4}$$

$$4(9a - 2) = 27a + 1$$

$$36a - 8 = 27a + 1$$

$$9a = 9$$

$$a = 1$$

**38.** The angle of elevation of the top Q of a vertical tower PQ from a point X on the ground is 60°. From a point Y 40 m vertically above X, the angle of elevation of the top Q of tower is 45°. Find the height of the PQ and the distance PX. (Use  $\sqrt{3} = 1.73$ ) [4]

**Ans :**

Let PX be x and PQ be h. As per given in question



we have drawn figure below.

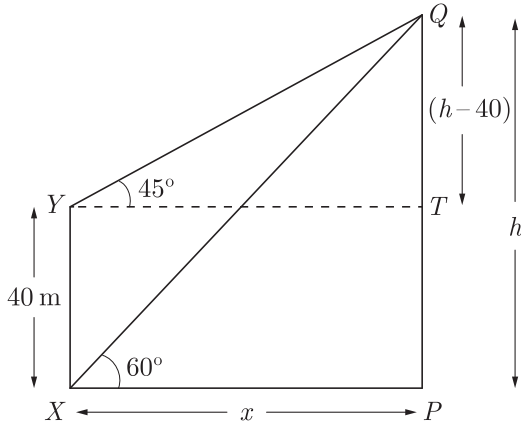

Now  $QT = (h - 40)$  m

In right  $\Delta PQX$ , we have,

$$\begin{aligned} \tan 60^\circ &= \frac{h}{x} \\ \sqrt{3} &= \frac{h}{x} \\ h &= \sqrt{3}x \end{aligned} \quad \dots(1)$$

In right  $\Delta QTY$  we have

$$\begin{aligned} \tan 45^\circ &= \frac{h - 40}{x} \\ 1 &= \frac{h - 40}{x} \\ x &= h - 40 \end{aligned} \quad \dots(2)$$

Solving (1) and (2), we get

$$\begin{aligned} x &= \sqrt{3}x - 40 \\ \sqrt{3}x - x &= 40 \\ (\sqrt{3} - 1)x &= 40 \\ x &= \frac{40}{\sqrt{3} - 1} = 20(\sqrt{3} + 1) \text{ m} \end{aligned}$$

Thus 
$$\begin{aligned} x &= \sqrt{3} \times 20(\sqrt{3} + 1) \\ &= 20(3 + \sqrt{3}) \text{ m} \\ &= 20(3 + 1.73) = 20 \times 4.73 \end{aligned}$$

Hence, height of tower is 94.6 m.

or

The tops of two towers of height  $x$  and  $y$ , standing on level ground, subtend angles of  $30^\circ$  and  $60^\circ$  respectively at the centre of the line joining their feet, then find  $x : y$ .

Ans :

Let  $AB$  be the tower of height  $x$  and  $CD$  be the tower of height  $y$ . Angle of depressions of both tower at centre point  $M$  are given  $30^\circ$  and  $60^\circ$  respectively. As per given in question we have drawn figure below.

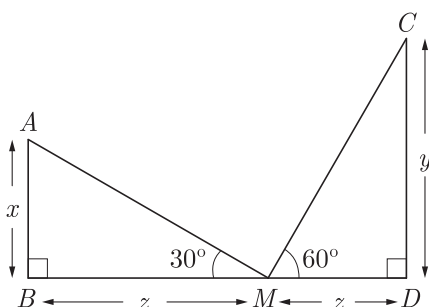

Here  $M$  is the centre of the line joining their feet.

Let  $BM = MD = z$

In right  $\Delta ABM$ , we have,

$$\begin{aligned} \frac{x}{z} &= \tan 30^\circ \\ x &= z \times \frac{1}{\sqrt{3}} \end{aligned}$$

In right  $\Delta CDM$ , we have

$$\begin{aligned} \frac{y}{z} &= \tan 60^\circ \\ y &= z \times \sqrt{3} \end{aligned}$$

From (1) and (2), we get

$$\begin{aligned} \frac{x}{y} &= \frac{z \times \frac{1}{\sqrt{3}}}{z \times \sqrt{3}} \\ \frac{x}{y} &= \frac{1}{3} \end{aligned}$$

Thus  $x : y = 1 : 3$

39. Prove that opposite sides of a quadrilateral circumscribing a circle subtend supplementary angles at the centre of the circle. [4]

Ans :

A circle centre  $O$  is inscribed in a quadrilateral  $ABCD$  as shown in figure given below.

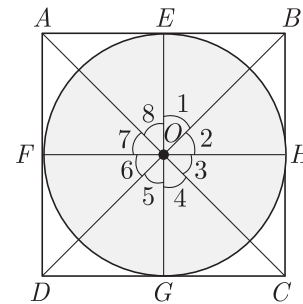

Since  $OE$  and  $OF$  are radius of circle

$$OE = OF \quad (\text{radii of circle})$$

Tangent drawn at any point of a circle is perpendicular to the radius through the point contact.

Thus  $\angle OEA = \angle OFA = 90^\circ$

Now in  $\Delta AEO$  and  $\Delta AFO$

$$OE = OF$$

$$\angle OEA = \angle OFA = 90^\circ$$

$$OA = OA \quad (\text{Common side})$$

Thus  $\Delta AEO \cong \Delta AFO$  (SAS congruency)

$$\angle 7 = \angle 8$$

Similarly,

$$\angle 3 = \angle 4$$

$$\angle 5 = \angle 6$$

Since angle around a point is  $360^\circ$ ,

$$\angle 1 + \angle 2 + \angle 3 + \angle 4 + \angle 5 + \angle 6 + \angle 7 + \angle 8 = 360^\circ$$

$$2\angle 1 + 2\angle 8 + 2\angle 4 + 2\angle 5 = 360^\circ$$

$$\angle 1 + \angle 8 + \angle 4 + \angle 5 = 180^\circ$$

$$(\angle 1 + \angle 8) + (\angle 4 + \angle 5) = 180^\circ$$

$$\angle AOB + \angle COD = 180^\circ$$

Hence Proved.

40. On the sports day of a school, 300 students participated.

Their ages are given in the following distribution :

Age (in years)	5-7	7-9	9-11	11-13	13-15	15-17	17-19
Number of students	67	33	41	95	36	13	15

Find the mean and mode of the data. [4]

**Ans :**

Here, Modal class = 11 – 13

$$l = 11, f_1 = 95, f_0 = 41, f_2 = 36, h = 2$$

$$\begin{aligned} \text{Mode} &= l + \frac{f_1 - f_0}{2f_1 - f_0 - f_2} \times h \\ &= 11 + \frac{95 - 41}{190 - 41 - 36} \times 2 \\ &= 11 + \frac{54}{113} \times 2 \end{aligned}$$

$$\text{Mode} = 11 + 0.95 = 11.95$$

Age	$x_i$	$f_i$	$f_i x_i$
5-7	6	67	402
7-9	8	33	264
9-11	10	41	410
11-13	12	95	1140
13-15	14	36	504
15-17	16	13	208
17-19	18	15	270
		$\sum f_i = 300$	$\sum f_i x_i = 3,198$

$$\begin{aligned} \text{Mean} &= \bar{x} = \frac{\sum f_i x_i}{\sum f_i} \\ &= \frac{3,198}{300} \\ &= 10.66 \end{aligned}$$

WWW.CBSE.ONLINE

Download unsolved version of this paper from  
www.cbse.online